

SFP 1.25Gb/s Transceiver SX 550m – ML-S85D-05
Hot Pluggable, Duplex LC, +3.3V, 850nm VCSEL-LD,DDMI



- ✧ Up to 550m on 50/125μm MMF
- ✧ Single +3.3V Power Supply
- ✧ Monitoring Interface Compliant with SFF-8472
- ✧ Low power dissipation <1W typically
- ✧ Industrial /Extended/ Commercial operating temperature range: 0°C to 70°C

Features:

- Up to 1.25Gb/s Data Links
- Hot-Pluggable
- 850nm VCSEL laser transmitter
- Duplex LC connector
- RoHS compliant and Lead Free

Applications:

- Metro/Access Networks
- 1.25 Gb/s 1000Base-SX Ethernet
- 1×Fiber Channel
- Other Optical Link

Description:

Opway' OP3405D Transceiver is a high performance, cost effective module which have a Duplex LC optics interface. Standard AC coupled CML for high speed signal and LVTTTL control and monitor signals.

The receiver section uses a PIN receiver and the transmitter uses 850 nm VCSEL laser, up to 8dB link budge ensure this module 1000Base Ethernet 550m application.

● **Absolute Maximum Ratings**

Parameter	Symbol	Min.	Typical	Max.	Unit
Storage Temperature	Ts	-40		+85	°C
Supply Voltage	Vcc	-0.5		4	V
Relative Humidity	RH	0		85	%

● **Recommended Operating Environment:**

Parameter	Symbol	Min.	Typical	Max.	Unit
Case operating Temperature	Tc				°C
		Commercial	0	+70	
Supply Voltage	Vcc	3.135		3.465	V
Supply Current	Icc			300	mA
Inrush Current	I _{surge}			Icc+30	mA
Maximum Power	P _{max}			1	W

● **Electrical Characteristics (T_{OP} = T_c, V_{CC} = 3.0 to 3.60 Volts)**

Parameter	Symbol	Min.	Typical	Max.	Unit	Note
Transmitter Section:						
Input differential impedance	R _{in}	90	100	110		
Single ended data input swing	V _{in PP}	250		1200	mVp-p	
Transmit Disable Voltage	V _D	V _{cc} – 1.3		V _{cc}	V	2
Transmit Enable Voltage	V _{EN}	V _{ee}		V _{ee} + 0.8	V	
Transmit Disable Assert Time	T _{dassert}			10	us	
Receiver Section:						
Single ended data output swing	V _{out,pp}	250		800	mv	3
LOS Fault	V _{losfault}	V _{cc} – 0.5		V _{CC_host}	V	5
LOS Normal	V _{los norm}	V _{ee}		V _{ee} +0.5	V	5
Power Supply Rejection	PSR	100			mVpp	6

Note:

1. AC coupled.
2. Or open circuit.
3. Into 100 ohm differential termination.
4. 20 – 80 %
5. LOS is LVTTTL. Logic 0 indicates normal operation; logic 1 indicates no signal detected.
6. All transceiver specifications are compliant with a power supply sinusoidal modulation of 20 Hz to 1.5MHz up to specified value applied through the power supply filtering network shown on page 23 of the Small Form-factor Pluggable (SFP) Transceiver Multi-Source Agreement (MSA), September 14, 2000.
7. Measured with DJ-free data input signal. In actual application, output DJ will be the sum of input DJ and . DJ.

● **Optical Parameters(T_{OP} = T_c, V_{CC} = 3.135 to 3.465 Volts)**

Parameter	Symbol	Min.	Typical	Max.	Unit	Note
Transmitter Section:						
Center Wavelength	λ _c	840	850	860	nm	
Spectral Width(RMS)	σ _{RMS}			0.85	nm	
Optical Output Power	P _{out}	-9		-3	dBm	1
Extinction Ratio	ER	9			dB	
Optical Rise/Fall Time	t _r / t _f			260	ps	2
Relative Intensity Noise	RIN			-120	dB/Hz	
Output Eye Mask	Compliant with IEEE802.3 z (class 1 laser safety)					
Receiver Section:						
Optical Input Wavelength	λ _c	770		860	nm	
Receiver Overload	P _{ol}	0			dBm	3
RX Sensitivity	Sen			-17	dBm	3
RX_LOS Assert	LOS _A	-35			dBm	
RX_LOS De-assert	LOS _D			-18	dBm	
RX_LOS Hysteresis	LOS _H	0.5			dB	

SFP 1.25Gb/s Transceiver SX 550m – ML-S85D-05
Hot Pluggable, Duplex LC, +3.3V, 850nm VCSEL-LD,DDMI



General Specifications:						
Data Rate	BR		1.25		Gb/s	
Bit Error Rate	BER			10 ⁻¹²		
Max. Supported Link Length on 50/125µm MMF@1.25Gb/s	L _{MAX}		550		m	
Total System Budget	LB	8			dB	

Note:

1. The optical power is launched into MMF.
2. 20-80%.
3. Measured with PRBS 27-1 at 10-12 BER

● **Digital Diagnostic Monitor Characteristics**

The following digital diagnostic characteristics are defined over the Recommended Operating Environment unless otherwise specified. It is compliant to SFF8472 Rev10.2 with internal calibration mode. For external calibration mode please contact our sales staff.

Parameter	Symbol	Min.	Max.	Unit
Temperature monitor absolute error	DMI_Temp	-3	3	degC
Laser power monitor absolute error	DMI_TX	-3	3	dB
RX power monitor absolute error	DMI_RX	-3	3	dB
Supply voltage monitor absolute error	DMI_VCC	-0.1	0.1	V
Bias current monitor absolute error	DMI_Ibias	-10%	10%	mA

● **Pin Assignment:**

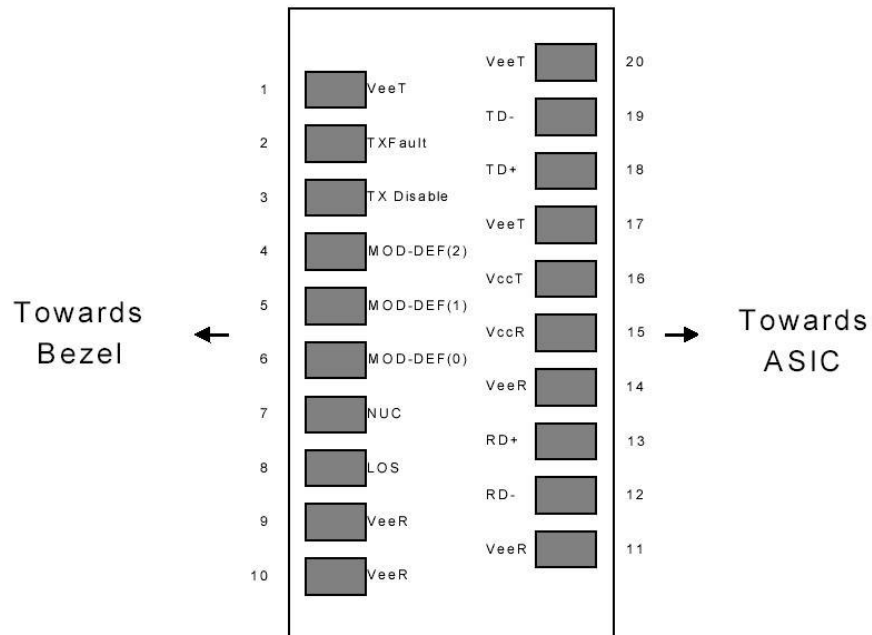

Figure2:Diagram of Host Board Connector Block Pin Numbers and Names

SFP 1.25Gb/s Transceiver SX 550m – ML-S85D-05
Hot Pluggable, Duplex LC, +3.3V, 850nm VCSEL-LD,DDMI



● **Pin Description:**

Pin No	Name	Function	Plug Seq	Notes
1	VeeT	Transmitter Ground	1	1
2	TX Fault	Transmitter Fault Indication	3	
3	TX Disable	Transmitter Disable	3	2
4	MOD-DEF2	Module Definition	2	3
5	MOD-DEF1	Module Definition 1	3	3
6	MOD-DEF0	Module Definition 0	3	3
7	Rate Select	Not Connected	3	4
8	LOS	Loss of Signal	3	5
9	VeeR	Receiver Ground	1	1
10	VeeR	Receiver Ground	1	1
11	VeeR	Receiver Ground		1
12	RD-	Inv. Received Data Out	3	6
13	RD+	Received Data Out	3	6
14	VeeR	Receiver Ground	3	1
15	VccR	Receiver Power	2	1
16	VccT	Transmitter Power	2	
17	VeeT	Transmitter Ground	1	
18	TD+	Transmit Data In	3	6
19	TD-	Inv. Transmit In	3	6
20	VeeT	Transmitter Ground	1	

Notes:

1. Circuit ground is internally isolated from chassis ground.
2. Laser output disabled on TDIS >2.0V or open, enabled on TDIS <0.8V.
3. Should be pulled up with 4.7k - 10 kohms on host board to a voltage between 2.0V and 3.6V. MOD_DEF(0) pulls line low to indicate module is plugged in.
4. Rate select is not used
5. LOS is open collector output. Should be pulled up with 4.7k – 10 kohms on host board to a voltage between 2.0V and 3.6V. Logic 0 indicates normal operation; logic 1 indicates loss of signal.
6. AC Coupled

● **SFP Module EEPROM Information and Management**

The SFP modules implement the 2-wire serial communication protocol as defined in the SFP -8472. The serial ID information of the SFP modules can be accessed through the I²C interface at address A0h.

Data Address	Length (Byte)	Name of Length	Description and Contents
Base ID Fields			
0	1	Identifier	Type of Serial transceiver (03h=SFP)
1	1	Reserved	Extended identifier of type serial transceiver (04h)
2	1	Connector	Code of optical connector type (07=LC)
3-10	8	Transceiver	Gigabit Ethernet 1000Base-SX & Fiber Channel
11	1	Encoding	8B/10B (01h)
12	1	BR,Nominal	Nominal baud rate, unit of 100Mbps
13	1	Reserved	(0000h)
14	1	Length(9um,km)	Link length supported for 9/125um fiber, units of km
15	1	Length(9um)	Link length supported for 9/125um fiber, units of 100m
16	1	Length(50um)	Link length supported for 50/125um fiber, units of 10m
17	1	Length(62.5um)	Link length supported for 62.5/125um fiber, units of 10m
18	1	Length(Copper)	Link length supported for copper, units of meters
19	1	Reserved	
20-35	16	Vendor Name	SFP vendor name:OPWAY
36	1	Reserved	
37-39	3	Vendor OUI	SFP transceiver vendor OUI ID
40-55	16	Vendor PN	Part Number: “OP3405D” (ASCII)
56-59	4	Vendor rev	Revision level for part number
60-61	2	Wavelength	Laser wavelength
62	1	Reserved	
63	1	CCID	Least significant byte of sum of data in address 0-62
Extended ID Fields			
64-65	2	Option	Indicates which optical SFP signals are implemented(001Ah = LOS, TX_FAULT, TX_DISABLE all supported)
66	1	BR, max	Upper bit rate margin, units of %
67	1	BR, min	Lower bit rate margin, units of %
68-83	16	Vendor SN	Serial number (ASCII)
84-91	8	Date code	Manufacturing date code
92	1	Diagnostic Type	Diagnostics
93	1	Enhanced Options	Diagnostics
94	1	SFF-8472	Diagnostics
95	1	CCEX	Check code for the extended ID Fields (addresses 64 to 94)
Vendor Specific ID Fields			
96-127	32	Readable	Vendor specific date, read only

● **Diagnostics Memory Contents(A2h):**

Data Address	Length (Byte)	Name of Length	Description and Contents
Diagnostic and control/status fields			
0-39	40	A/W Thresholds	Diagnostic Flag Alarm and Warning Thresholds
40-55	16	Unallocated	
56-91	16	Ext Cal Constants	Diagnostic calibration constants for optional External Calibration
92-94	3	Unallocated	
95	1	CC_DMI	Check code for Base Diagnostic Fields (addresses 0 to 94)
96-105	10	Diagnostics	Diagnostic Monitor Data (internally or externally calibrated)
106-109	4	Unallocated	
110	1	Status/Control	Optional Status and Control Bits
111	1	Reserved	Reserved for SFF-8079
112-113	2	Alarm Flags	Diagnostic Alarm Flag Status Bits
114-115	2	Unallocated	
116-117	2	Warning Flags	Diagnostic Warning Flag Status Bits
118-119	2	Ext Status/Control	Extended module control and status bytes
General use fields			
120-127	8	Vendor Specific	Vendor specific memory addresses
128-247	120	User EEPROM	User writable non-volatile memory
248-255	8	Vendor Control	Vendor specific control addresses

● **Regulatory Compliance**

Feature	Standard	Performance
Electrostatic Discharge (ESD) to the Electrical Pins	MIL-STD-883E Method 3015.7	Class 1
Electrostatic Discharge (ESD) to the Duplex LC Receptacle	IEC 61000-4-2 GR-1089-CORE	Compatible with standards
Electromagnetic Interference (EMI)	FCC Part 15 Class B EN55022 Class B (CISPR 22B) VCCI Class B	Compatible with standards
Laser Eye Safety	FDA 21CFR 1040.10 and 1040.11 EN60950, EN (IEC) 60825-1,2	Compatible with Class I laser product. -
RoHS	2002/95/EC 4.1&4.2 2005/747/EC	Compliant with standards

● **References**

1. IEEE Std 802.3, 2002 Edition, Clause 38, PMD Type 1000BASE-SX.IEEE Standards Department, 2002.
2. “Fibre Channel Physical and Signaling Interface (FC-PH, FC-PH2, FC-PH3)”.American National Standard for Information Systems.
3. “Fibre Channel Draft Physical Interface Specification (FC-PI 13.0)”. American National Standard for Information Systems.
4. Small Form-factor Pluggable (SFP) Transceiver Multi-source Agreement (MSA) September 14, 2000.

● **Recommended Circuit:**

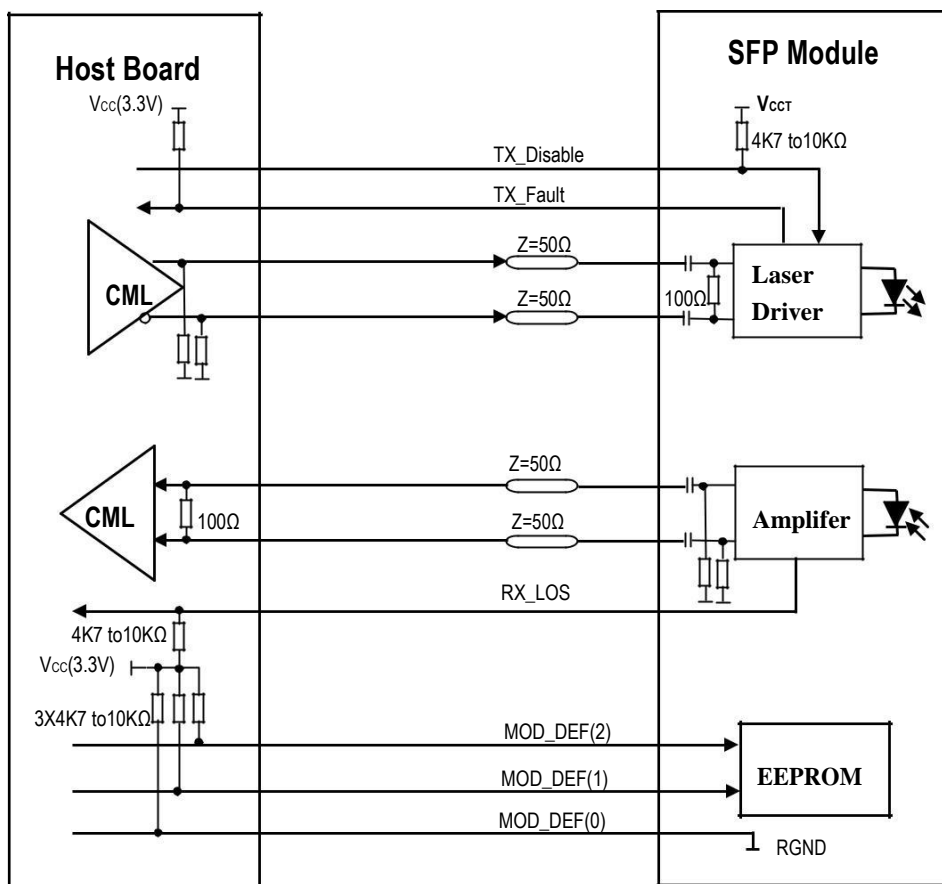

Figure 5. SFP Host Recommended Circuit

SFP 1.25Gb/s Transceiver SX 550m – ML-S85D-05
Hot Pluggable, Duplex LC, +3.3V, 850nm VCSEL-LD,DDMI



● **Mechanical Dimensions:**

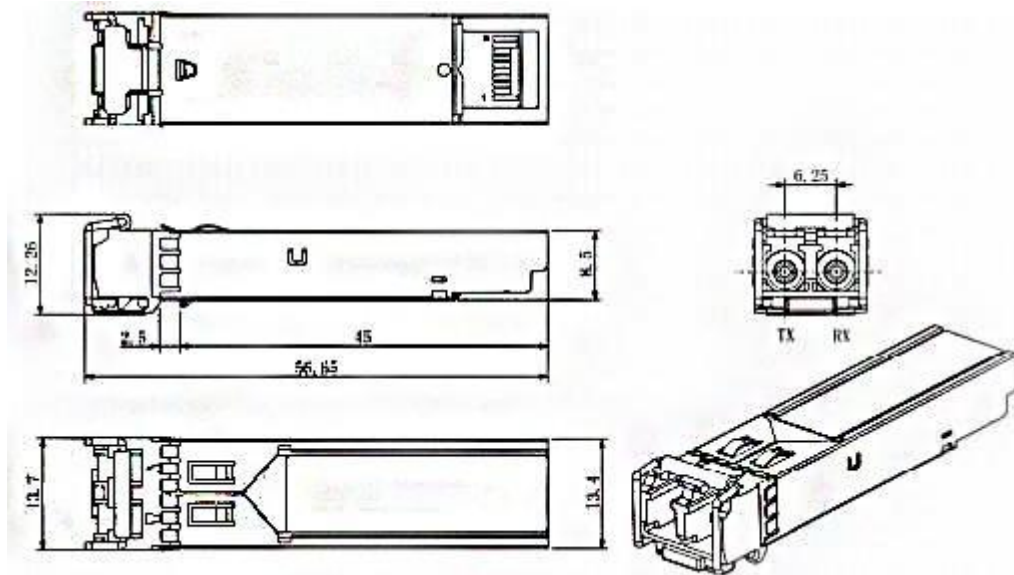

Figure 6. Mechanical Drawing