

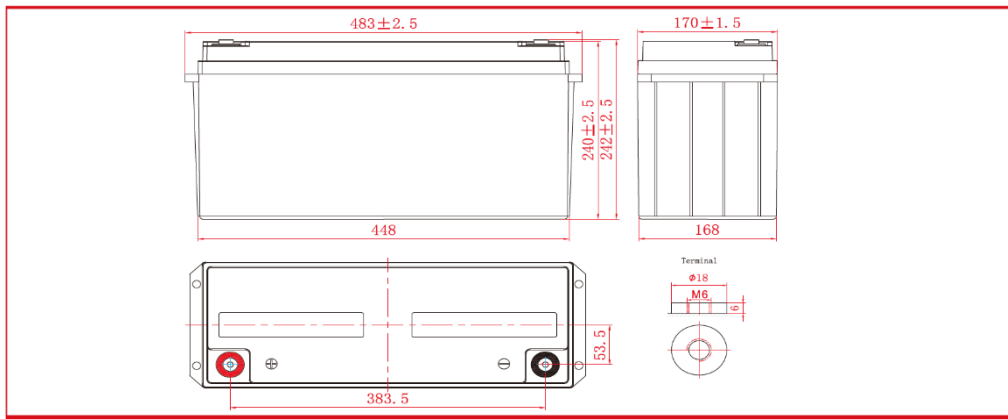

Maxlink batteries use high purity raw materials and low density electrolyte to make the batteries have good cycle performance and low self-discharge rate. It is suitable for UPS, solar & wind energy, telecom system, electric power system.

Cells per unit:	6
Voltage per unit:	12
Capacity:	150Ah @ 20hr-rate to 1.75V per cell @25°C (77°F)
Weight:	Approx. 40.2kg
Maximum discharge current:	1300A (5sec)
Internal resistance:	Approx. 4.2 mΩ
Operating temperature range:	Discharge -15°C ~ 50°C Charge -15°C ~ 40°C Storage -15°C ~ 40°C
Nominal operating temp. range:	25°C +/- 3°C
Float charging voltage:	13.5 to 13.8VDC / unit, average at 25°C
Recommended max. charging current limit:	38A
Equalization and cycle service:	14.4 to 15VDC / unit, average at 25°C
Self discharge:	Can be stored for more than 6 months at 25°C, please charge batteries before using.
Connector:	2x M6
Battery Dimensions:	240 x 483 x 170 mm +/- 2.5mm



(A)25°C Constant Current Discharge

F.V/Time	30min	1h	2h	3h	5h	10h	20h
1.60V	147	88.5	55.7	37.2	24.9	14.2	7.60
1.67V	144	87.2	54.9	36.8	24.8	14.2	7.57
1.70V	142	86.3	54.3	36.7	24.6	14.2	7.54
1.75V	137	83.5	52.5	36.0	24.2	14.1	7.50
1.80V	130	79.9	50.3	34.6	23.6	13.9	7.36
1.85V	122	74.0	46.6	31.8	21.9	13.3	7.13

(W/cell)25°C Constant Power Discharge

F.V/Time	30min	1h	2h	3h	5h	10h	20h
1.60V	277	168	106	73.3	48.6	28.0	14.9
1.67V	273	166	105	72.6	48.5	27.9	14.9
1.70V	270	165	104	72.1	48.3	27.9	14.8
1.75V	261	162	102	70.7	47.6	27.7	14.7
1.80V	249	156	98.1	68.2	46.4	27.3	14.5
1.85V	233	147	92.6	63.3	43.6	26.4	14.1

Temperature Effects on Long Term Float Life

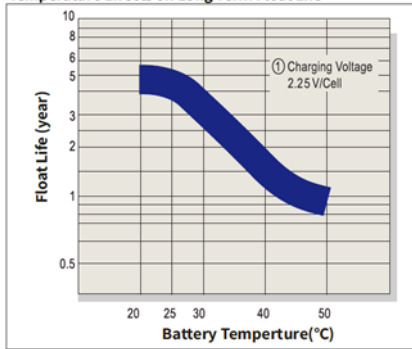

The effect of temperature on capacity

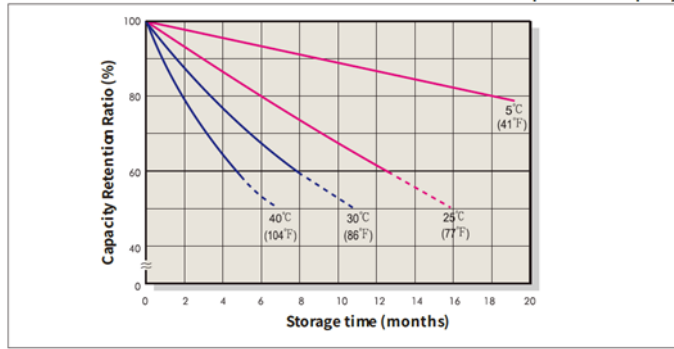

Float Charging Characteristics

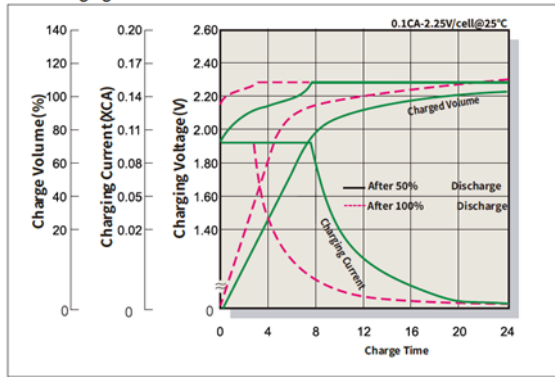

Discharge Characteristics

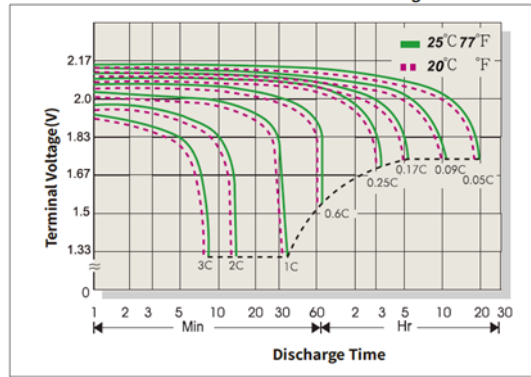

The effect of temperature on capacity(20HR)

Temperature	Capacity(20HR)
40°C	102%
25°C	100%
0°C	85%
-15°C	65%

Self-discharge characteristics

Storage time	The remaining capacity
3 months	91%
6 months	82%
12 months	64%